



SAW Bandpass Filter Specifications

Unit Name	SAW Bandpass Filter
Part Name	SY204167B
Date	February 4, 2004

Written by	Checked by	Approved by



Systron Inc.
1274 - 3rd Avenue South
Lethbridge, Alberta
T1J 0J9 Canada

Phone: (403) 327-1444
Fax: (403) 327-1480
e-mail: sales@systroninc.com

1. Features

- IF Bandpass Filter
- Low-Loss Filter
- Single-Ended Operation
- Ceramic Surface Mount Device (SMD) Package
- Maximum Storage Temperature Range : -40 °C ~ 85 °C
- Electrostatics Sensitive Device (ESD)

2. Package Dimensions

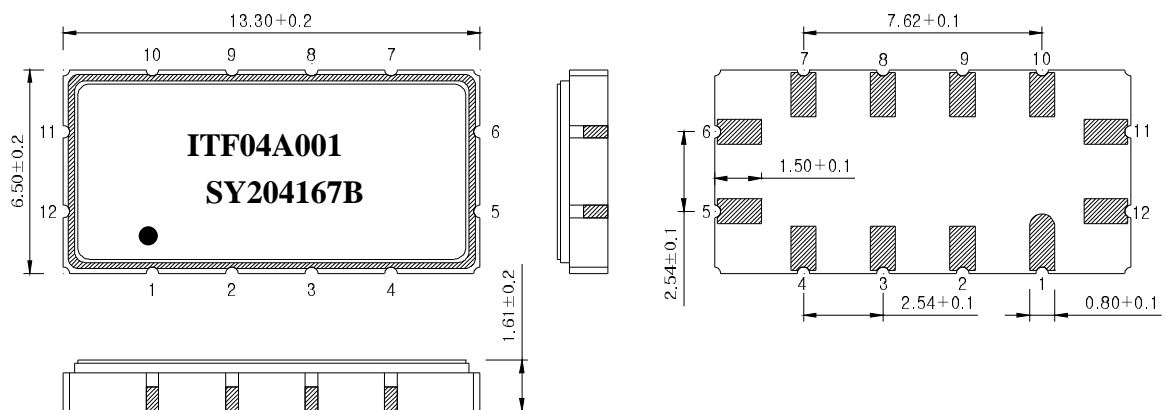

Package : S1365

Dimensions shown are nominal in millimeters

Body : Al₂O₃ Ceramic

Lid : Kovar, Ni Plated

Terminations : Au plating 0.3 ~ 1.0 um, Over a 1.27 ~ 8.89 um Ni Plating

Pad Configuration	
11	Input
5	Output
6, 12	Ground
Other	Case ground

3. Specifications

Fo = 70.0 MHz

Terminating source impedance : 50Ω and matching network

Terminating load impedance : 50Ω and matching network

		Minimum	Typical	Maximum
Center Frequency	MHz	69.95	70.0	70.05
Insertion Loss	dB	-	11.0	12.5
1dB Bandwidth	MHz	-	1.1	-
3dB Bandwidth	MHz	1.5	1.6	-
40dB Bandwidth	MHz	-	3.15	3.3
Amplitude Ripple (Fo +/- 0.3 MHz)	dB	-	0.5	0.8
Group Delay Variation (Fo +/- 0.3 MHz)	nsec	-	180	250
Absolute Delay	usec	-	1.67	-
Ultimate Rejection	dB	40	45	-
Temperature Coefficient of Frequency	ppm/°C	-	-23	-

Notes :

- 1) All specifications are based on the matching schematic shown below
- 2) All specifications are measured by Agilent Network analyzer and full 2 port calibration at room temperature
- 3) All attenuation measurements are measured relative to insertion loss

4. Matching Schematic

(Actual matching values may vary due to PCB layout and parasitics)

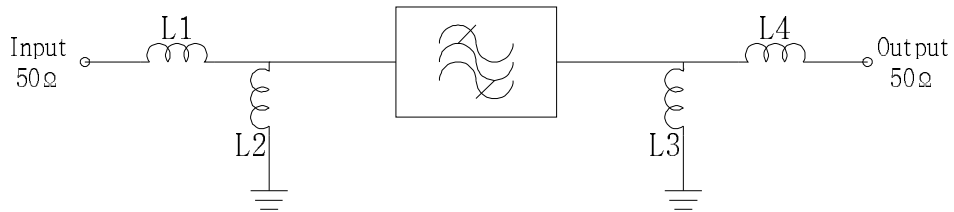

L1 = 150 nH,

L4 = 150 nH

L2 = 220 nH

L3 = 220 nH

5. Marking Configuration

ITF04A001¹⁾

SY204167B²⁾

●³⁾

1) Lot Number

2) Part Number

3) Pad Number 1 Index

6. Typical Performance (at +25°C)

