



SAW Bandpass Filter Specifications

Unit Name	SAW Bandpass Filter
Part Name	SY206162B
Date	April 27, 2004

Written by	Checked by	Approved by



Systron Inc.
1274 - 3rd Avenue South
Lethbridge, Alberta
T1J 0J9 Canada

Phone: (403) 327-1444
Fax: (403) 327-1480
e-mail: sales@systroninc.com

1. Features

- IF Bandpass Filter
- Low-Loss Filter
- Single-Ended Operation
- Ceramic Surface Mount Device (SMD) Package
- Maximum Storage Temperature Range : -40°C ~ 85°C
- Electrostatics Sensitive Device (ESD)

2. Package Dimensions

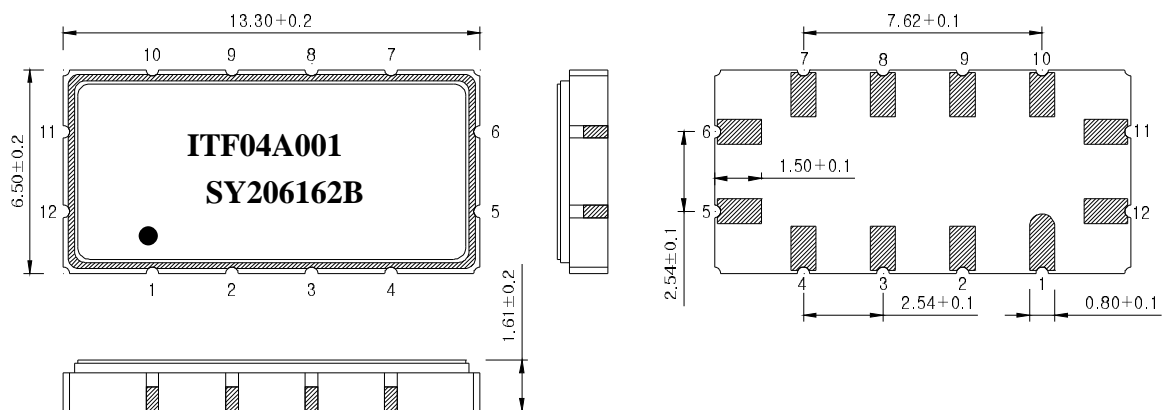

Package : S1365

Dimensions shown are nominal in millimeters

Body : Al₂O₃ Ceramic

Lid : Kovar, Ni Plated

Terminations : Au plating 0.3 ~ 1.0 um, Over a 1.27 ~ 8.89 um Ni Plating

Pad Configuration	
11	Input
5	Output
6, 12	Ground
Other	Case ground

3. Specifications

Fo = 70.0 MHz

Terminating source impedance : 50Ω and matching network

Terminating load impedance : 50Ω and matching network

		Minimum	Typical	Maximum
Center Frequency	MHz	69.8	70.0	70.2
Insertion Loss	dB	-	17.5	18.5
1dB Bandwidth	MHz	-	30.1	-
3dB Bandwidth	MHz	30.8	31.2	-
40dB Bandwidth	MHz	-	36.8	38.0
Amplitude Ripple (Fo +/- 13.5 MHz)	dB	-	0.7	1.0
Group Delay Variation (Fo +/- 13.5 MHz)	nsec	-	30	90
Absolute Delay	usec	-	0.9	-
Ultimate Rejection	dB	40	45	-
Temperature Coefficient of Frequency	ppm/°C	-	-86	-

Notes :

- 1) All specifications are based on the matching schematic shown below
- 2) All specifications are measured by Agilent Network analyzer and full 2 port calibration at room temperature
- 3) All attenuation measurements are measured relative to insertion loss

4. Matching Schematic

(Actual matching values may vary due to PCB layout and parasitics)



L1 = 180 nH, L2 = 120 nH

5. Marking Configuration

ITF04A001¹⁾

SY206162B²⁾

●³⁾

1) Lot Number

2) Part Number

3) Pad Number 1 Index

6. Typical Performance (at +25°C)

